

2010

Product Catalog

ROHM
SEMICONDUCTOR

Discrete Semiconductors

Schottky Barrier Diodes Zener Diodes



ROHM Co.,Ltd.

Schottky Barrier Diodes

Original fine process technology and a unique device structure have enabled ROHM to develop Schottky barrier diodes that feature simultaneously low V_F and I_R - an unprecedented accomplishment - for higher efficiency, lower loss, and greater reliability. As a result, the RSX Series commands a large market share.

The RB series, widely used in industrial, commercial, and automotive applications, is available in both surface mount and axial package types.

ROHM offers a wide range of packages, from the industry's smallest (GMD2: 0603 size) to standard high power types (TO-220), enabling selection of the ideal solution to meet virtually any need.

Zener Diodes

ROHM offers Zener diodes in a variety of sizes, including one of the smallest on the market - in the 0603-sized GMD2 package. In addition, ultra-low capacitance models (0.3pF) are available optimized for use as ESD surge protection devices in automotive systems and high-speed signal lines (i.e. USB2.0).

The RSB Series offers bidirectional (positive/negative) surge protection in a single package, ideal for use in high density and portable applications of all types, including mobile phones and next-generation automotive systems.

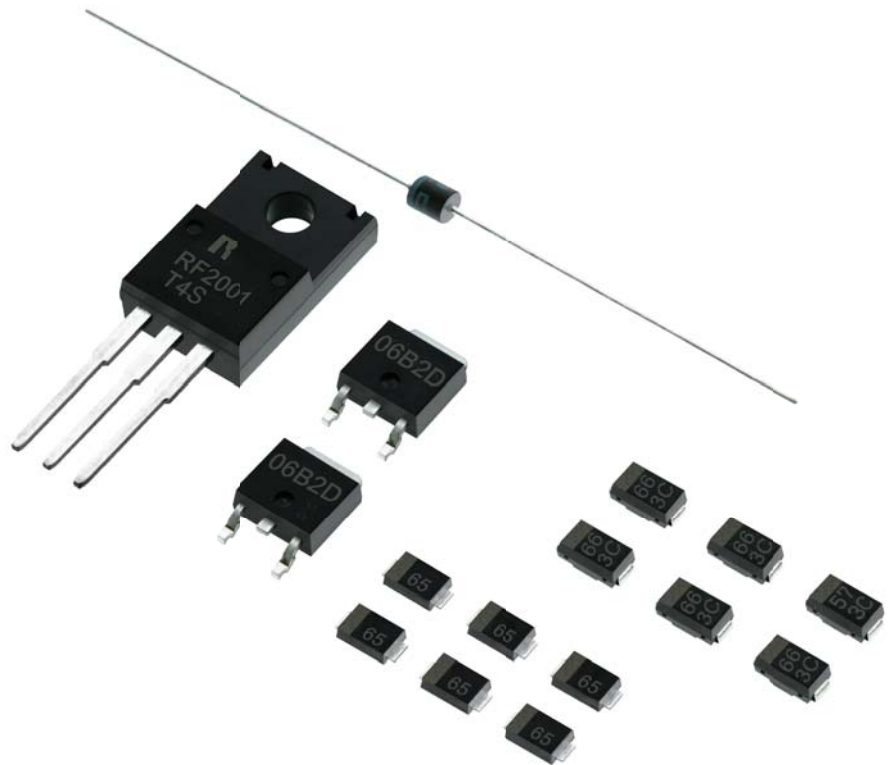

Contents

High Efficiency High Reliability Surface Mount Type	3
Ultra-Compact 0603-Sized Schottky Barrier Diodes	4
Small Signal Schottky Barrier Diodes	5
Middle Power Schottky Barrier Diodes	7
Power Diodes (Including High Efficiency High Reliability Leaded Models)	9
2-Terminal (Single) Zener Diodes	10
Compact, High Reliability 1W Constant Voltage Diodes	11
Low Capacitance Zener Diodes	12
Bi-directional Zener Diodes	13
Schottky Barrier Diode Lineup	14
Zener Diode Product Lineup	17
Dimensions	20

High Efficiency High Reliability Surface Mount Type

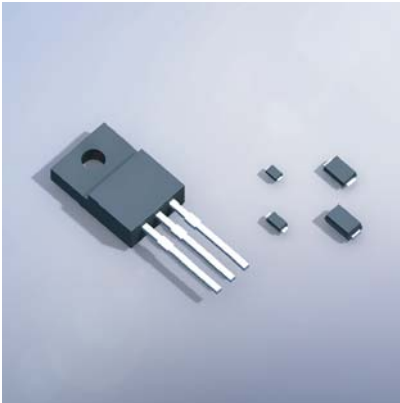

RSX Series

Summary

Simultaneous low V_F and low I_R have been achieved through utilization of original precision processes and device configuration. High ESD resistance is enabled as well.

Features

- Low V_F
- Low I_R
- High surge resistance
- High reliability

Applications

- Switches
- Rectifiers

Low V_F · Low I_R

Generally, there is a trade-off between V_F (Forward Voltage) and I_R (Reverse Current).

ROHM's RSX series, however, feature simultaneously low V_F and I_R by utilizing proprietary precision processes and device configuration.

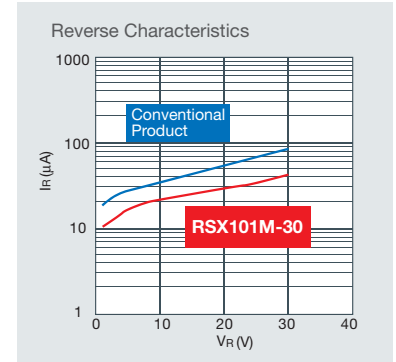
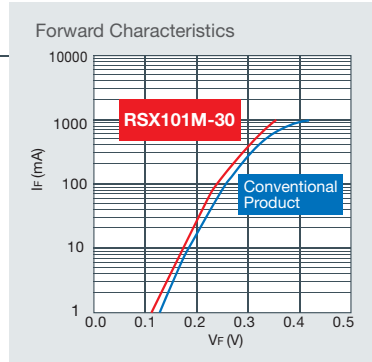

High ESD resistance for greater reliability

Conventional Schottky barrier diodes possess weaker ESD resistance than even PN junction diodes.

ROHM's RSX series, on the other hand, features greater resistance to ESD than conventional products due to utilization of advanced processes and a unique device configuration.

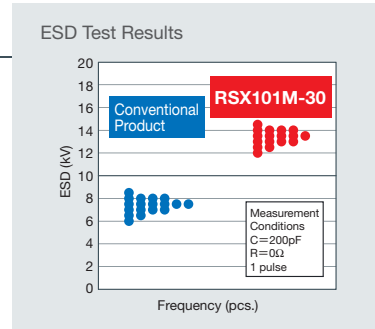

Lineup

Product No.		Absolute Maximum Ratings (Ta=25°C)*1				Electrical Characteristics (Ta=25°C)*1				Package	Equivalent Circuit Diagram
Part No.	Taping Code	V _{RM} (V)	V _R (V)	I _O (A)	I _{FSM} (A) 60Hz, 1ms	V _F (V)		I _R (mA)			
						Max.	I _F (A)	Max.	V _R (V)		
RSX051VA-30	TR	30	30	0.5	5.0	0.39	0.5	0.20	30	TUMD2	
RSX071VA-30	TR	30	30	0.7	5.0	0.42	0.7	0.20	30	TUMD2	
RSX101VA-30	TR	30	30	1	5.0	0.47	1.0	0.20	30	TUMD2	
New RSX201VA-30	TR	30	30	1.5	8.0	0.46	1.5	0.30	30	TUMD2	
RSX101M-30	TR	30	30	1	45	0.39	1.0	0.20	30	PMDU	
RSX301LA-30	TR	30	30	3	70	0.42	3.0	0.20	30	PMDT	
RSX501LA-20	TR	25	20	5	70	0.39	3.0	0.50	20	PMDT	
RSX201L-30	TE25	30	30	2	60	0.44	2.0	0.15	30	PMDS	
New RSX205L-30	TE25	30	30	2	60	0.49	2.0	0.20	30	PMDS	
RSX301L-30	TE25	30	30	3	70	0.42	3.0	0.20	30	PMDS	
RSX501L-20	TE25	25	20	5	70	0.39	3.0	0.50	20	PMDS	
RSX1001T3	Bulk	30	30	10	150	0.44	5.0	0.5	30	TO-220FN	

*1 : Value / Element

Ultra-Compact* 0603-Sized Schottky Barrier Diodes



GMD2 Package

Summary

ROHM has developed the industry's first* commercial Schottky barrier diodes in the 0603 size (0.6mm×0.3mm, t=0.3mm). (Package power is the same as the VMN2 – 100mW)

Features

- Ultra-small
- Ultra-thin

Applications

- Switches
- Rectifiers

* ROHM July 2009 survey

Space-Saving

ROHM has developed the industry's first* 0603-sized products utilizing an original chip structure combined with proprietary ultra-precise processing technology. Ideal for mobile phones and other portable electronic devices seeking to minimize size.

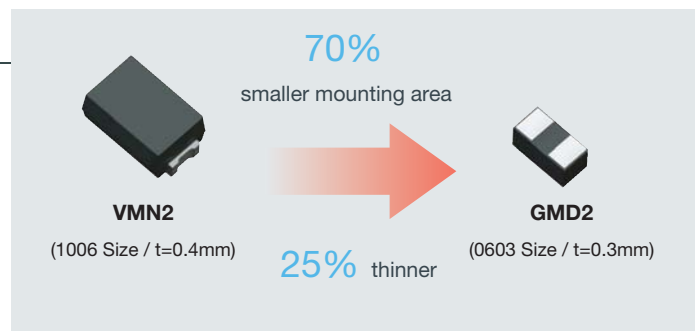

Dimensions

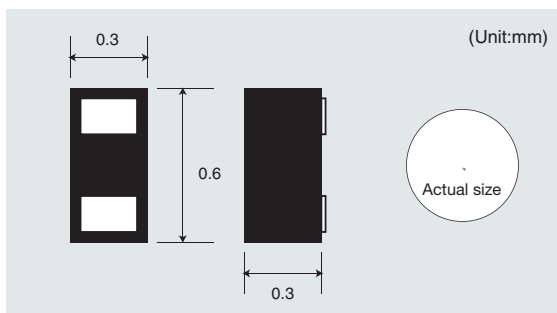

Lineup

Product No.		Absolute Maximum Ratings (Ta=25°C)*1				Electrical Characteristics (Ta=25°C)*1				Package	Equivalent Circuit Diagram
Part No.	Taping Code	V _{RM} (V)	V _R (V)	I _O (mA)	I _{FSM} (A) 60Hz.1~	V _F (V)		I _R (μA)			
						Max.	I _F (mA)	Max.	V _R (V)		
RB521ZS-30	T2R	30	30	100	0.5	0.37	10	7	10	GMD2	
RB520ZS-30	T2R	30	30	100	0.5	0.46	10	0.3	10	GMD2	

*1 : Value / Element

Small Signal Schottky Barrier Diodes

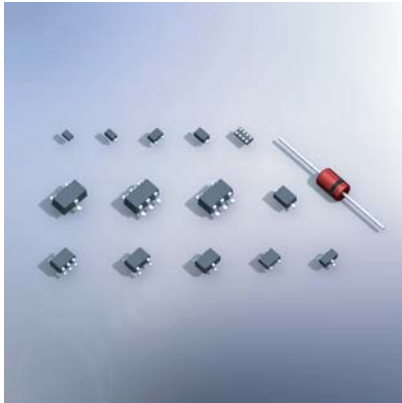

RB Series

Summary

ROHM's SBD lineup features high ESD and IFSM resistance with simultaneously low V_F and low I_R .

Features

- Switches
- Rectifiers

Applications

- Small
- High performance

Ultra-compact multi-chip type (HMD8)

An original chip device structure, combined with ultra-fine processing technology, enable the configuration of multiple diodes in a single package. Internal circuitry and connections are completely customizable to suit user needs.

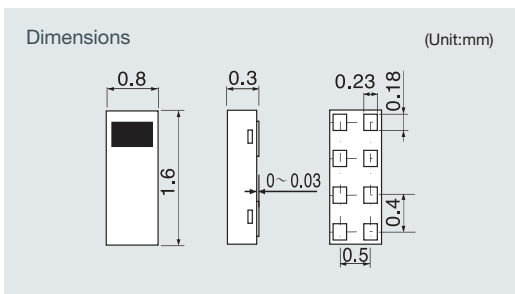

Superior low V_F , low I_R characteristics

Optimization of device conditions has enabled low V_F and low I_R .

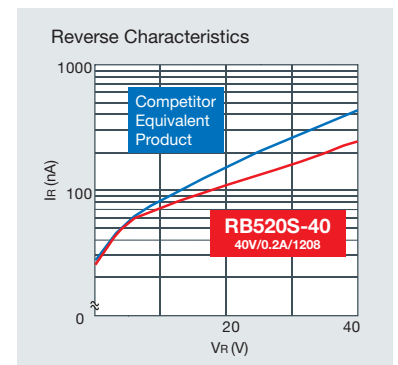
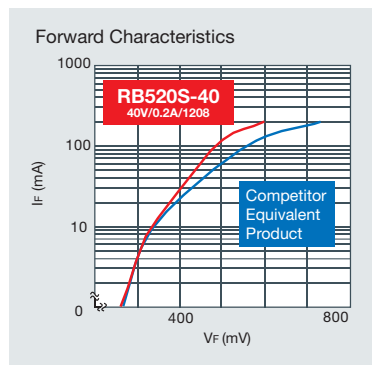

Saves space

ROHM offers a broad lineup of high-density single-, dual-, and triple-element models that contribute to end-product miniaturization.

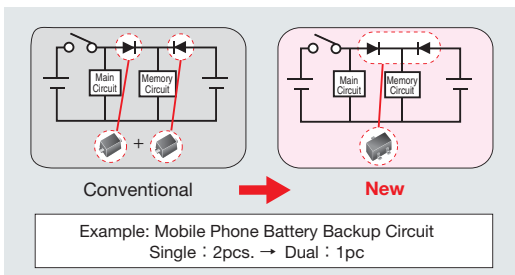

High ESD, high IFSM resistance

Device optimization ensures high ESD and IFSM tolerance.

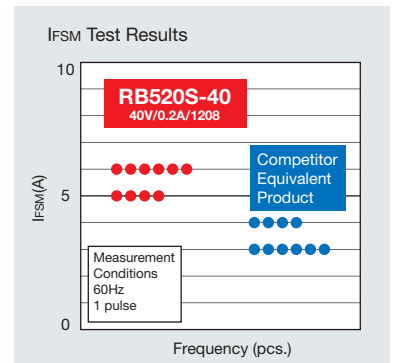
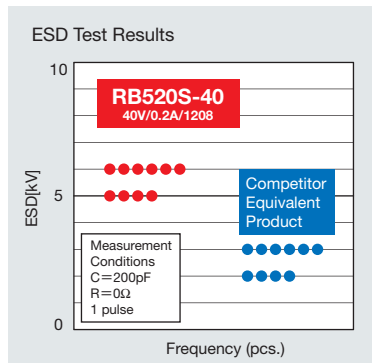

Lineup

■ Single Type

Product No.		Absolute Maximum Ratings (Ta=25°C)*1				Electrical Characteristics (Ta=25°C)*1				Package	Equivalent Circuit Diagram
Part No.	Packaging Symbol	V _{RM} (V)	V _R (V)	I _O (mA)	I _{FSM} (A) 60Hz.1 ~	V _F (V) Max.	I _F (mA)	I _R (μA) Max.	V _R (V)		
RB521CS-30	T2R	—	30	100	0.5	0.35	10	10	10	VMN2	
RB520CS-30	T2R	—	30	100	0.5	0.45	10	0.5	10	VMN2	
RB751CS-40	T2R	40	30	30	0.2	0.37	1	0.5	30	VMN2	
RB521G-30	T2R	—	30	100	0.5	0.35	10	10	10	VMD2	
RB520G-30	T2R	—	30	100	0.5	0.45	10	0.5	10	VMD2	
RB751G-40	T2R	40	30	30	0.2	0.37	1	0.5	30	VMD2	
RB521S-30	TE61	—	30	200	1	0.5	200	30	10	EMD2	
RB520S-30	TE61	—	30	200	1	0.6	200	1	10	EMD2	
RB531S-30	TE61	—	30	100	0.5	0.35	10	10	10	EMD2	
RB530S-30	TE61	—	30	100	0.5	0.45	10	0.5	10	EMD2	
RB751S-40	TE61	40	30	30	0.2	0.37	1	0.5	30	EMD2	
RB521S-40	TE61	45	40	200	4	0.45	0.1	90	40	EMD2	
RB520S-40	TE61	40	40	200	1	0.55	100	10	40	EMD2	
RB751V-40	TE-17	40	30	30	0.2	0.37	1	0.5	30	UMD2	
RB501V-40	TE-17	45	40	100	1	0.55	100	30	10	UMD2	
RB500V-40	TE-17	45	40	100	1	0.45	10	1	10	UMD2	
RB721Q-40	T-77	40	40	30	0.2	0.37	1	0.5	25	MSD	
RB441Q-40	T-77	40	40	100	1	0.55	100	100	40	MSD	
RB451F	T106	40	40	100	1	0.55	100	30	10	UMD3	
RB450F	T106	45	40	100	1	0.45	10	1	10	UMD3	
RB421D	T146	40	40	100	1	0.55	100	30	10	SMD3	
RB420D	T146	40	40	100	1	0.45	10	1	10	SMD3	

Note: *1 Rating per element.

■ Dual Type

Product No.		Absolute Maximum Ratings (Ta=25°C)*1				Electrical Characteristics (Ta=25°C)*1				Package	Equivalent Circuit Diagram
Part No.	Packaging Symbol	V _{RM} (V)	V _R (V)	I _O (mA)	I _{FSM} (A) 60Hz.1 ~	V _F (V) Max.	I _F (mA)	I _R (μA) Max.	V _R (V)		
RB715Z	T2L	40	40	30	0.2	0.37	1	1	10	VMD3	
RB715W	TL	40	40	30	0.2	0.37	1	1	10	EMD3	
RB715F	T106	40	40	30	0.2	0.37	1	1	10	UMD3	
RB495D	T146	40	25	*2 400	2	0.5	200	70	25	SMD3	
RB705D	T146	40	40	30	0.2	0.37	1	1	10	SMD3	
RB425D	T146	40	40	100	1	0.55	100	30	10	SMD3	
RB717F	T106	40	40	30	0.2	0.37	1	1	10	UMD3	
RB557W	TL	—	30	100	0.5	0.35	10	10	10	EMD3	
RB558W	TL	—	30	100	0.5	0.35	10	10	10	EMD3	
RB548W	TL	—	30	100	0.5	0.45	10	0.5	10	EMD3	
RB706F-40	T106	45	40	30	0.2	0.37	1	1	10	UMD3	
RB706D-40	T146	45	40	30	0.2	0.37	1	1	10	SMD3	
RB481Y	T2R	—	30	100	1	0.43	100	30	10	EMD4	
RB480Y	T2R	—	30	100	1	0.53	100	1	10	EMD4	
RB481Y-40	T2R	40	40	200	1	0.45	100	90	40	EMD4	
RB480Y-40	T2R	40	40	200	1	0.55	100	10	40	EMD4	
RB481Y-90	T2R	90	90	100	1	0.61	100	100	90	EMD4	
RB480Y-90	T2R	90	90	100	1	0.69	100	5	90	EMD4	
RB481K	TL	30	30	200	1	0.5	200	30	10	UMD4	
RB480K	TL	45	40	100	1	0.6	100	1	10	UMD4	
RB471E	T148	40	40	100	1	0.55	100	30	10	SMD5	

Note: *1 Rating per element. *2 Value / 2 circuits.

■ Triple Type

Product No.		Absolute Maximum Ratings (Ta=25°C)*1				Electrical Characteristics (Ta=25°C)*1				Package	Equivalent Circuit Diagram
Part No.	Packaging Symbol	V _{RM} (V)	V _R (V)	I _O (mA)	I _{FSM} (A) 60Hz.1 ~	V _F (V) Max.	I _F (mA)	I _R (μA) Max.	V _R (V)		
RB531XN	TR	—	30	100	1	0.43	100	30	10	UMD6	
RB530XN	TR	—	30	100	1	0.53	100	1	10	UMD6	
New RB541XN	TR	—	30	100	0.5	0.35	10	10	10	UMD6	
RB731XN	TR	40	40	30	0.2	0.37	1	1	10	UMD6	
RB731U	T108	40	40	30	0.2	0.37	1	1	10	SMD6	

Note: *1 Rating per element.

■ Multi Type

Product No.		Absolute Maximum Ratings (Ta=25°C)*1				Electrical Characteristics (Ta=25°C)*1				Package	Equivalent Circuit Diagram
Part No.	Packaging Symbol	V _{RM} (V)	V _R (V)	I _O (mA)	I _{FSM} (A) 60Hz.1 ~	V _F (V) Max.	I _F (mA)	I _R (μA) Max.	V _R (V)		
New RB521ZS8A30	TE61	30	30	100	0.5	0.37	10	9	10	HMD8	

Note: *1 Rating per element.

Middle Power Schottky Barrier Diodes

RB Series

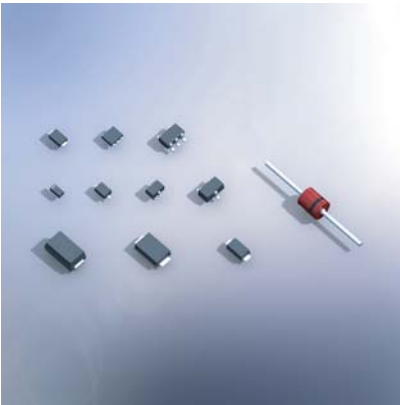

Summary

The lineup includes compact, low-profile packages, such as a 1608-sized product with $I_o=1A$.

Features

- Small
- High surge resistance

Applications

- Switches
- Rectifiers

1A=I_o in the 1608 size

A proprietary chip device structure, combined with proven ultra-precise process technology, ensures an output current of 1A in the 1608 size.

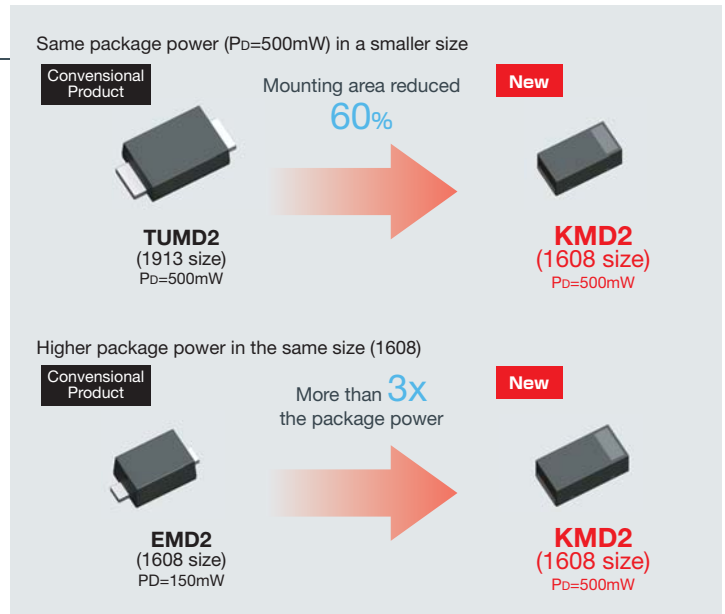
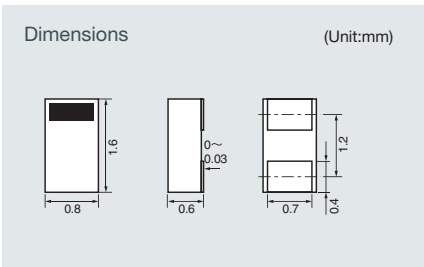

Simultaneous low V_F and I_R

Optimization of device conditions has enabled low V_F and low I_R .

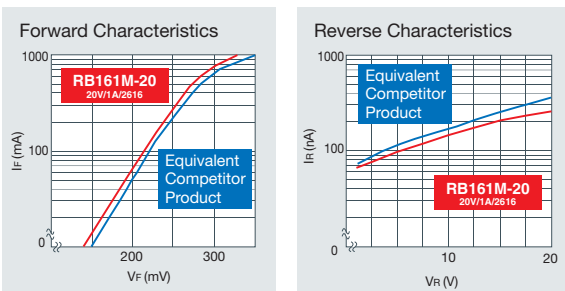

High ESD resistance · High I_{FSM} resistance

ROHM's unique wire-free configuration ensures higher I_{FSM} tolerance and ESD resistance than comparable models for greater surge protection and reliability.

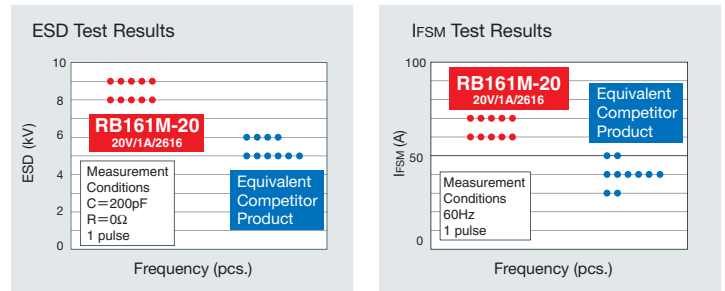

Lineup

■ Single Type

Product No.		Absolute Maximum Ratings (Ta=25°C)*				Electrical Characteristics (Ta=25°C)*				Package	Equivalent Circuit Diagram	
Part No.	Packaging Symbol	V _{RM} (V)	V _R (V)	I _O (A)	I _{FSM} (A) 60Hz, 1ms	V _F (V) Max.	I _F (A)	I _R (mA) Max.	V _R (V)			
New	RB551SS-30	T2R	30	20	0.5	5	0.47	0.5	0.1	20	KMD2	
New	RB550SS-30	T2R	30	30	0.5	5	0.59	0.5	0.008	15	KMD2	
New	RB161SS-20	T2R	30	20	1	5	0.42	1	1	20	KMD2	
New	RB160SS-40	T2R	40	40	1	5	0.55	0.7	0.05	20	KMD2	
	RB551V-30	TE-17	30	20	0.5	2	0.36	0.1	0.1	20	UMD2	
	RB161VA-20	TR	30	20	1	5	0.42	1	1	20	TUMD2	
	RB162VA-20	TR	25	20	1	5	0.40	1	1.2	20	TUMD2	
	RB550VA-30	TR	30	30	1	3	0.52	1	0.03	10	TUMD2	
	RB160VA-40	TR	40	40	1	5	0.55	0.7	0.05	40	TUMD2	
	RB411VA-50	TR	50	20	0.5	3	0.5	0.5	0.03	10	TUMD2	
	RB400VA-50	TR	50	40	0.5	3	0.55	0.5	0.05	30	TUMD2	
	RB021VA-90	TR	90	90	0.2	5	0.49	0.2	0.9	90	TUMD2	
	RB161M-20	TR	25	20	1	30	0.35	1	0.7	20	PMDU	
	RB051M-2Y	TR	20	20	3	30	0.46	3	0.9	20	PMDU	
	RB160M-30	TR	30	30	1	30	0.48	1	0.05	30	PMDU	
	RB070M-30	TR	30	30	1.5	30	0.49	1.5	0.05	30	PMDU	
	RB060M-30	TR	30	30	2	55	0.49	2	0.05	30	PMDU	
New	RB050M-30	TR	30	30	3	55	0.51	3	0.05	30	PMDU	
	RB160M-40	TR	40	40	1	30	0.51	1	0.03	40	PMDU	
	RB162M-40	TR	40	40	1	30	0.55	1	0.1	40	PMDU	
	RB160M-60	TR	60	60	1	30	0.55	1	0.05	60	PMDU	
	RB162M-60	TR	60	60	1	20	0.65	1	0.1	60	PMDU	
New	RB060M-60	TR	60	60	2	30	0.61	2	0.05	60	PMDU	
	RB160M-90	TR	90	90	1	30	0.73	1	0.1	90	PMDU	
	RB050LA-30	TR	—	30	3	70	0.45	3	0.15	30	PMDT	
	RB050LA-40	TR	40	40	3	70	0.55	3	0.1	40	PMDT	
	RB051LA-40	TR	40	20	3	70	0.45	3	1	20	PMDT	
	RB055LA-40	TR	40	40	3	70	0.62	3	0.1	40	PMDT	
	RB081L-20	TE25	25	20	5	70	0.45	5	0.7	20	PMDS	
New	RB055L-30	TE25	30	30	3	55	0.55	3	0.05	30	PMDS	
New	RB080L-30	TE25	30	30	5	70	0.51	5	0.15	30	PMDS	
	RB161L-40	TE25	40	20	1	70	0.4	1	1	20	PMDS	
	RB051L-40	TE25	40	20	3	70	0.45	3	1	20	PMDS	
	RB160L-40	TE25	40	40	1	70	0.55	1	0.1	40	PMDS	
	RB162L-40	TE25	40	40	1	20	0.55	1	0.5	40	PMDS	
	RB060L-40	TE25	40	40	2	70	0.5	2	1	40	PMDS	
	RB050L-40	TE25	40	40	3	70	0.55	3	1	40	PMDS	
	RB055L-40	TE25	40	40	3	40	0.65	3	0.5	40	PMDS	
	RB056L-40	TE25	40	40	3	70	0.67	3	0.05	40	PMDS	
	RB160L-60	TE25	60	60	1	30	0.58	1	1	60	PMDS	
	RB162L-60	TE25	60	60	1	20	0.65	1	0.1	60	PMDS	
	RB050L-60	TE25	60	60	2	70	0.52	2	0.1	60	PMDS	
	RB160L-90	TE25	95	90	1	30	0.73	1	0.1	90	PMDS	
	RB160A30	T-32	30	30	1	70	0.48	1	0.05	30	MSR	
	RB160A40	T-32	40	40	1	50	0.55	1	0.03	40	MSR	
	RB160A60	T-32	60	60	1	60	0.55	1	0.05	60	MSR	
	RB160A90	T-32	90	90	1	50	0.73	1	0.1	90	MSR	
	RB201A60	T-32	60	60	2	40	0.58	2	0.1	60	MSR	
	RB461F	T106	25	20	0.7	3	0.49	0.7	0.2	20	UMD3	
	RB491D	T146	25	20	1	3	0.45	1	0.2	20	SMD3	
	RB411D	T146	40	20	0.5	3	0.5	0.5	0.03	10	SMD3	
	RB400D	T146	40	40	0.5	3	0.55	0.5	0.05	30	SMD3	

Note: *1 Rating per element.

■ Dual Type

Product No.		Absolute Maximum Ratings (Ta=25°C)*				Electrical Characteristics (Ta=25°C)*				Package	Equivalent Circuit Diagram	
Part No.	Packaging Symbol	V _{RM} (V)	V _R (V)	I _O (A)	I _{FSM} (A) 60Hz, 1ms	V _F (V) Max.	I _F (A)	I _R (mA) Max.	V _R (V)			
	RB496KA	TR	—	20	1	5	0.43	1	0.8	10	TUMD5	
	RB496EA	TR	20	20	1	10	0.4	1	0.5	10	TSMD5	
	RB550EA	TR	30	30	0.7	15	0.49	0.7	0.05	30	TSMD5	

Note: *1 Rating per element.

Power Diodes (Includes High Efficiency High Reliability Leaded Models)



RB Series

Summary

The lineup includes conventional high power products as well as power diodes featuring a voltage resistance of 100V.

Features

- Low V_F
- Low I_R
- High surge resistance

Applications

- Switches
- Rectifiers

Superior low V_F , low I_R characteristics

ROHM's diodes feature high efficiency conversion with low V_F for low heat generation and lower losses with low I_R , even when running warm.

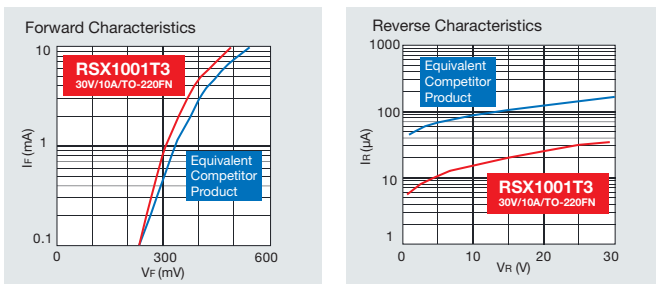

High ESD and I_{FSM} resistance

Precision processes and a unique device configuration have resulted in a higher ESD resistance than conventional products.

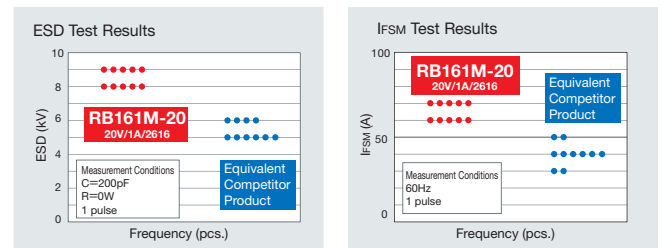

Lineup

Product No.		Absolute Maximum Ratings (Ta=25°C) *1				Electrical Characteristics (Ta=25°C) *1				Package	Equivalent Circuit Diagram
Part No.	Packaging Symbol	V _{RM} (V)	V _R (V)	I _O *2 (A)	I _{FSM} (A) 60Hz, 1ms	V _F (V) Max.	I _F (A)	I _R (mA) Max.	V _R (V)		
RB095B-30	TL	35	30	6	45	0.425	3	0.2	30	D-Pack (CPD)	
RB095B-40	TL	45	40	6	45	0.55	3	0.1	40		
RB095B-60	TL	60	60	6	45	0.58	3	0.15	60		
RB095B-90	TL	90	90	6	45	0.75	3	0.15	90		
RB085B-30	TL	35	30	10	35	0.48	4	0.3	30		
RB085B-40	TL	45	40	10	45	0.55	5	0.2	40		
RB085B-90	TL	90	90	10	45	0.83	5	0.15	90	D-Pack (CPD)	
RB075B40S	TL	40	40	5	45	0.75	5	0.005	40		
RB225N-40	TL	40	40	30	50	0.55	15	0.5	40	LPDS	
RB095T-40	Bulk	45	40	6	100	0.55	3	0.1	40	TO-220FN	
RB085T-40	Bulk	45	40	10	100	0.55	5	0.2	40		
RB205T-40	Bulk	45	40	15	100	0.55	7.5	0.3	40		
RB215T-40	Bulk	45	40	20	100	0.55	10	0.5	40		
RB225T-40	Bulk	40	40	30	100	0.63	15	0.5	40		
RB095T-60	Bulk	60	60	6	100	0.58	3	0.1	60		
RB085T-60	Bulk	60	60	10	100	0.58	5	0.3	60		
RB205T-60	Bulk	60	60	15	100	0.58	7.5	0.6	60		
RB215T-60	Bulk	60	60	20	100	0.58	10	0.6	60		
RB225T-60	Bulk	60	60	30	100	0.63	15	0.6	60		
RB095T-90	Bulk	90	90	6	100	0.75	3	0.15	90		
RB085T-90	Bulk	90	90	10	100	0.83	5	0.15	90		
RB205T-90	Bulk	90	90	15	100	0.78	7.5	0.3	90		
RB215T-90	Bulk	90	90	20	100	0.75	10	0.4	90		
RB225T100	Bulk	100	100	30	100	0.88	15	0.4	100		

Note: *1 Value / element. *2 1/2 lo per diode.

2-Terminal (Single) Zener Diodes

Ultra-compact 0603-sized package



Summary

The industry's first* 0603-sized (0.6mm×0.3mm, t=0.3mm) low voltage diode is now available. (Package power is 100mW, equivalent to the VMN2.)

Features

- Ultra-compact
- Ultra-low profile

Applications

- Compact, low-profile, high density sets of all types

Space-saving

Ideal for mobile phones and other portable electronic devices requiring the utmost in miniaturization.

ROHM has developed the industry's first* 0603-sized products using an original chip device structure and proprietary ultra-fine precision processing technology.

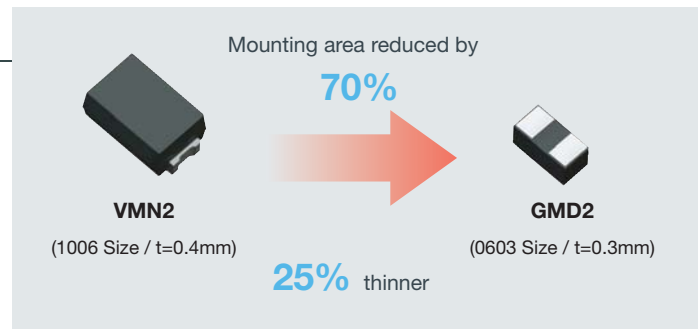

Dimensions

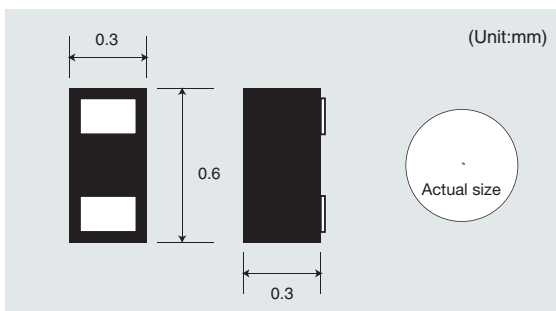

Absolute Maximum Ratings

Permissible Loss	P	: 100mW
Junction Temperature	T _j	: 125°C
Storage Temperature	T _{stg}	: -55 to 125°C
Operating Temperature	T _{opr}	: -55 to 125°C

Electrical Characteristics

T_a=25°C

Part No.	Zener Voltage V _z (V)		Measurement Conditions I _z (mA)
	Min.	Max.	
GDZ3.9	3.740	4.160	5.0
GDZ4.7	4.420	4.900	5.0
GDZ5.1	4.840	5.370	5.0
GDZ5.6	5.310	5.920	5.0
GDZ6.2	5.860	6.530	5.0
GDZ6.8	6.470	7.140	5.0
GDZ7.5	7.060	7.840	5.0
GDZ8.2	7.760	8.640	5.0

Compact, High Reliability 1W Constant Voltage Diodes



KDZ Series

Summary

High 1W power in the compact 2616 size.

Features

- Compact
- High power

Applications

- Automotive
- Manufacturing
- Power supplies

Same ESD protection in a smaller package.

A new lineup of 1W zener diodes in the 2616 size is offered, featuring the same ESD resistance as conventional 4526-size products.

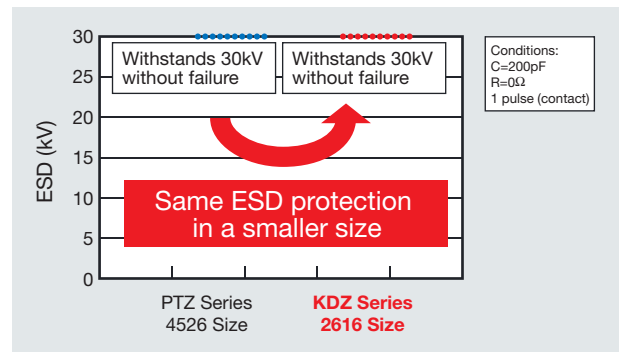
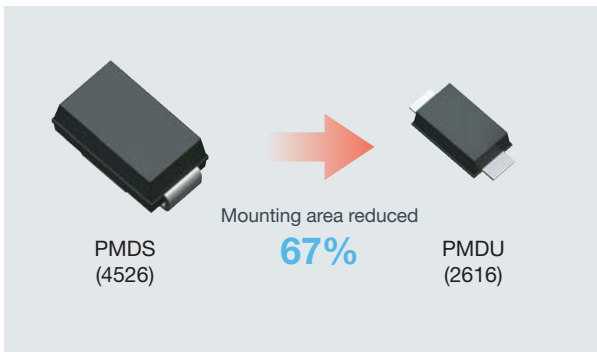

1W diode in the 2616 size

	PTZ Series	KDZ Series
Package	PMDS 4.5mm × 2.6mm (t=1.1mm)	PMDU 2.6mm × 1.6mm (t=0.8mm)
P	1W	1W
Vz rank	3.6 to 39V	3.6 to 39V

Absolute Maximum Ratings

Permissible Loss	P : 1W
Junction Temperature	T _J : 150°C
Storage Temperature	T _{stg} : -55 to 150°C
Operating Temperature	T _{opr} : -55 to 150°C

Electrical Characteristics

T_a=25°C

Part No.	Zener Voltage Vz(V)		Measurement Conditions I _z (mA)
	Min.	Max.	
KDZ3.6B	3.60	4.00	40
KDZ3.9B	3.90	4.40	40
KDZ4.3B	4.30	4.80	40
KDZ4.7B	4.70	5.20	40
KDZ5.1B	5.10	5.70	40
KDZ5.6B	5.60	6.30	40
KDZ6.2B	6.20	7.00	40
KDZ6.8B	6.80	7.70	40
KDZ7.5B	7.50	8.40	40
KDZ8.2B	8.20	9.30	40
KDZ9.1B	9.10	10.20	40
KDZ10B	10.00	11.20	40
KDZ11B	11.00	12.30	20
KDZ12B	12.00	13.50	20
KDZ13B	13.30	15.00	20
KDZ15B	14.70	16.50	20
KDZ16B	16.20	18.30	20
KDZ18B	18.00	20.30	20
KDZ20B	20.00	22.40	20
KDZ22B	22.00	24.50	10
KDZ24B	24.00	27.60	10
KDZ27B	27.00	30.80	10
KDZ30B	30.00	34.00	10
KDZ33B	33.00	37.00	10
KDZ36B	36.00	40.00	10

Low Capacitance Zener Diodes



Optimized for ESD surge protection on High-speed signal lines

Summary

High-reliability USB2.0-compatible Zener diodes.

Features

- Compact
- Ultra-low profile
- Low inter-pin capacitance

Applications

- Mobile phones
- Notebook PCs
- DSCs / DVCs
- LCDs / PDPs

Low capacitance zener characteristics

Normal Zener

When the inter-pin capacitance is large (30 to 50pF) the signal becomes rounded

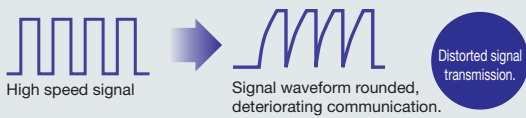

Low Capacitance Zener

Inter-pin capacitance is small (1 to 8pF)



High ESD resistance

Normally, lower C_t indicates lower ESD protection. However...

ROHM provides simultaneous low C_t (1pF) and high ESD (13kV)

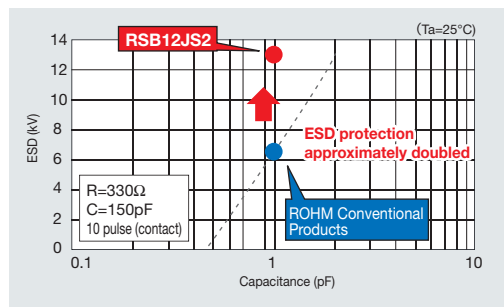

RSB12JS2 (Ta=25°C)	
	EMD6 (1612 Size)
Permissible Loss	150mW / Total
Storage Temperature	-55 to 150°C
Zener Voltage	9.6V to 14.4V
Reverse Current	0.1μA Max.
Capacitance Between Pins	1pF typ.

Lineup

Part No.	Absolute Maximum Ratings (Ta=25°C)		Electrical Characteristics (Ta=25°C)				Package	Equivalent Circuit Diagram
	P (mW)	V _Z (V)	I _Z (mA)	C _t (pF)	f (MHz)	V _R (V)		
UMZU6.2N	200	5.9 to 6.5	5	8	1	0	UMD3	
FTZU6.2E	200	5.9 to 6.5	5	8	1	0	SMD5	
CDZC6.8B	100	6.65 to 6.93	5	3	1	0	VMN2	
EDZC6.8B	150	6.65 to 6.93	5	3	1	0	EMD2	
EMZC6.8N	150	6.47 to 7.14	5	3	1	0	EMD3	
VMZT6.8N	150	6.47 to 7.14	5	7	1	0	UMD3	
UMZC6.8N	200	6.47 to 7.14	5	3	1	0	UMD3	
STZC6.8N	200	6.47 to 7.14	5	3	1	0	SMD3	
RSB12Z	100	9.6 to 14.4	5	1	1	0	VMD3	
RSB12W	150	9.6 to 14.4	5	1	1	0	EMD3	
EMZT6.8E	150	6.47 to 7.14	5	7	1	0	EMD5	
New RSB6.8JS2	150	6.00 to 8.00	5	1	1	0	EMD6	
RSB12JS2	150	9.6 to 14.4	5	1	1	0	EMD6	
New RSAC6.8CS	100	6.70 to 7.33	5	0.3	1	0	VMN2	
New RSAC16CS	100	16.49 to 17.51	5	0.3	1	0	VMN2	
New RSB6.8CS	100	6.62 to 7.24	5	1	1	0	VMN2	

* : The (3) and (6) pin should be OPEN.

Bidirectional Zener Diodes

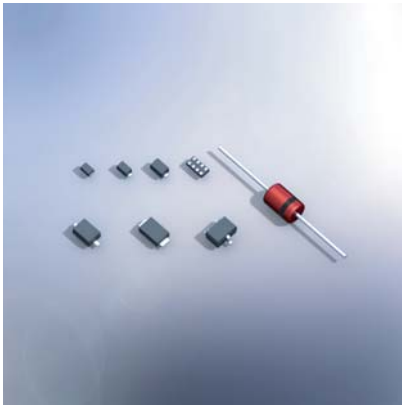

Bidirectional surge absorption (positive/negative) in a single package

Summary

Protects against both positive and negative surges, reducing the number of components required.

Features

- Compact
- Saves space

Applications

- Portable equipment
- DSC / DVCs
- Mobile phones
- Automotive

Protects against forward and reverse surges.

ROHM's zener diodes offer bidirectional surge protection, reducing both parts count and set size.

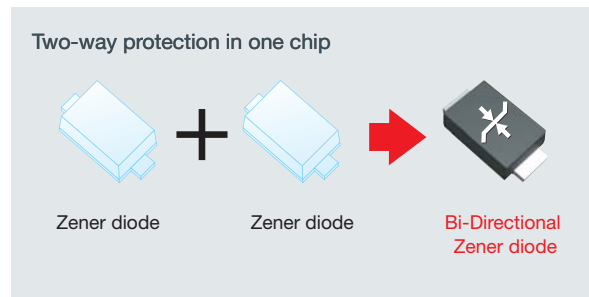
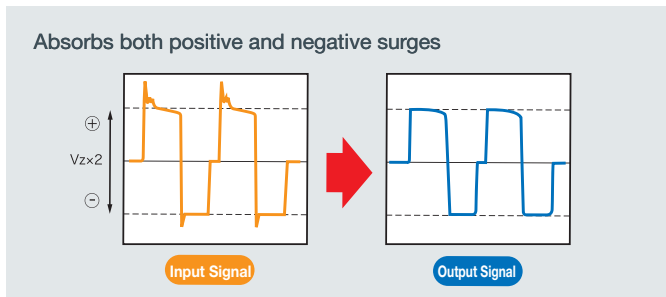

High reliability

The TUMD2 package features improved heat dissipation and 500mW package power. Ideal for CAN/LIN bus lines.

Circuit Example

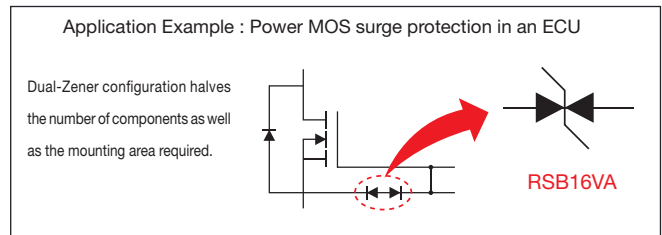

Lineup

Part No.	Absolute Maximum Ratings (Ta=25°C)		Electrical Characteristics (Ta=25°C)		Remarks	Package	Equivalent Circuit Diagram
	P (mW)	Vz (V)	Iz (mA)				
RSB6.8CS	100	5.78 to 7.82	1			VMN2	
RSB6.8G	100	5.78 to 7.82	1			VMD2	
RSB5.6S	150	4.76 to 6.44	1			EMD2	
RSB6.8S	150	5.78 to 7.82	1			EMD2	
RSB16V	200	14.4 to 17.6	1		IEC61000-4-2	UMD2	
RSB18V	200	16.2 to 19.8	1		150pF, 330Ω	UMD2	
RSB27V	200	26.2 to 32.0	1		Contact 8kV	UMD2	
RSB16VA	500	14.4 to 17.6	1		In air 15kV	TUMD2	
RSB6.8F2	200	5.78 to 7.82	1			UMD3	
RSB16F2	200	14.4 to 17.6	1			UMD3	
RSB18F2	200	16.2 to 19.8	1			UMD3	
RSB27F2	200	26.2 to 32.0	1			UMD3	

Schottky Barrier Diode Lineup

High Efficiency High Reliability Surface Mount Type - RSX Series ($I_o \geq 0.5A$)

Product No.		Absolute Maximum Ratings (Ta=25°C) *				Electrical Characteristics (Ta=25°C) *				Package	Equivalent Circuit Diagram
Part No.	Packaging Symbol	V _{RM} (V)	V _R (V)	I _o (A)	I _{FSM} (A) 60Hz, 1 \sim	V _F (V) Max.	I _F (A)	I _R (mA) Max.	V _R (V)		
RSX051VA-30	TR	30	30	0.5	5.0	0.39	0.5	0.20	30	TUMD2	
RSX071VA-30	TR	30	30	0.7	5.0	0.42	0.7	0.20	30	TUMD2	
RSX101VA-30	TR	30	30	1	5.0	0.47	1.0	0.20	30	TUMD2	
New RSX201VA-30	TR	30	30	1.5	8.0	0.46	1.5	0.30	30	TUMD2	
RSX101M-30	TR	30	30	1	45	0.39	1.0	0.20	30	PMDU	
RSX301LA-30	TR	30	30	3	70	0.42	3.0	0.20	30	PMDT	
RSX501LA-20	TR	25	20	5	70	0.39	3.0	0.50	20	PMDT	
RSX201L-30	TE25	30	30	2	60	0.44	2.0	0.15	30	PMDS	
New RSX205L-30	TE25	30	30	2	60	0.49	2.0	0.20	30	PMDS	
RSX301L-30	TE25	30	30	3	70	0.42	3.0	0.20	30	PMDS	
RSX501L-20	TE25	25	20	5	70	0.39	3.0	0.50	20	PMDS	
RSX1001T3	Bulk	30	30	10	150	0.44	5.0	0.5	30	TO-220FN	

Note : * Value / Element.

Small Signal Schottky Barrier Diodes ($I_o < 0.5A$)

Product No.		Absolute Maximum Ratings (Ta=25°C) *1				Electrical Characteristics (Ta=25°C) *1				Package	Equivalent Circuit Diagram
Part No.	Packaging Symbol	V _{RM} (V)	V _R (V)	I _o (mA)	I _{FSM} (A) 60Hz, 1 \sim	V _F (V) Max.	I _F (mA)	I _R (μA) Max.	V _R (V)		
RB521ZS-30	T2R	30	30	100	0.5	0.37	10	7	10	GMD2	
RB520ZS-30	T2R	30	30	100	0.5	0.46	10	0.3	10	GMD2	
RB521CS-30	T2R	—	30	100	0.5	0.35	10	10	10	VMN2	
RB520CS-30	T2R	—	30	100	0.5	0.45	10	0.5	10	VMN2	
RB751CS-40	T2R	40	30	30	0.2	0.37	1	0.5	30	VMN2	
RB521G-30	T2R	—	30	100	0.5	0.35	10	10	10	VMD2	
RB520G-30	T2R	—	30	100	0.5	0.45	10	0.5	10	VMD2	
RB751G-40	T2R	40	30	30	0.2	0.37	1	0.5	30	VMD2	
RB521S-30	TE61	—	30	200	1	0.5	200	30	10	EMD2	
RB520S-30	TE61	—	30	200	1	0.6	200	1	10	EMD2	
RB531S-30	TE61	—	30	100	0.5	0.35	10	10	10	EMD2	
RB530S-30	TE61	—	30	100	0.5	0.45	10	0.5	10	EMD2	
RB751S-40	TE61	40	30	30	0.2	0.37	1	0.5	30	EMD2	
RB521S-40	TE61	45	40	200	4	0.45	0.1	90	40	EMD2	
RB520S-40	TE61	40	40	200	1	0.55	100	10	40	EMD2	
RB751V-40	TE-17	40	30	30	0.2	0.37	1	0.5	30	UMD2	
RB501V-40	TE-17	45	40	100	1	0.55	100	30	10	UMD2	
RB500V-40	TE-17	45	40	100	1	0.45	10	1	10	UMD2	
RB721Q-40	T-77	40	40	30	0.2	0.37	1	0.5	25	MSD	
RB441Q-40	T-77	40	40	100	1	0.55	100	100	40	MSD	
New RB521ZS8A30	TE61	30	30	100	0.5	0.37	10	7	10	HMD8	
RB715Z	T2L	40	40	30	0.2	0.37	1	1	10	VMD3	
RB715W	TL	40	40	30	0.2	0.37	1	1	10	EMD3	
RB715F	T106	40	40	30 *2	0.2	0.37	1	1	10	UMD3	
RB495D	T146	40	25	400	2	0.5	200	70	25	SMD3	
RB705D	T146	40	40	30	0.2	0.37	1	1	10	SMD3	
RB425D	T146	40	40	100	1	0.55	100	30	10	SMD3	
RB717F	T106	40	40	30	0.2	0.37	1	1	10	UMD3	
RB557W	TL	—	30	100	0.5	0.35	10	10	10	EMD3	
RB558W	TL	—	30	100	0.5	0.35	10	10	10	EMD3	
RB548W	TL	—	30	100	0.5	0.45	10	0.5	10	EMD3	
RB706F-40	T106	45	40	30	0.2	0.37	1	1	10	UMD3	
RB706D-40	T146	45	40	30	0.2	0.37	1	1	10	SMD3	
RB451F	T106	40	40	100	1	0.55	100	30	10	UMD3	
RB450F	T106	45	40	100	1	0.45	10	1	10	UMD3	
RB421D	T146	40	40	100	1	0.55	100	30	10	SMD3	
RB420D	T146	40	40	100	1	0.45	10	1	10	SMD3	
RB481Y	T2R	—	30	100	1	0.43	100	30	10	EMD4	
RB480Y	T2R	—	30	100	1	0.53	100	1	10	EMD4	
RB480Y-40	T2R	40	40	200	1	0.55	100	10	40	EMD4	
RB481Y-40	T2R	40	40	200	1	0.45	100	90	40	EMD4	
RB481Y-90	T2R	90	90	100	1	0.61	100	100	90	EMD4	
RB480Y-90	T2R	90	90	100	1	0.69	100	5	90	EMD4	
RB481K	TL	30	30	200	1	0.5	200	30	10	UMD4	
RB480K	TL	45	40	100	1	0.6	100	1	10	UMD4	
RB471E	T148	40	40	100	1	0.55	100	30	10	SMD5	
RB531XN	TR	—	30	100	1	0.43	100	30	10	UMD6	
RB530XN	TR	—	30	100	1	0.53	100	1	10	UMD6	
New RB541XN	TR	—	30	100	0.5	0.35	10	10	10	UMD6	
RB731XN	TR	40	40	30	0.2	0.37	1	1	10	UMD6	
RB731U	T108	40	40	30	0.2	0.37	1	1	10	SMD6	

Note: *1 Value / Element *2 1/2 I_o per diode.

■ Middle Power Schottky Barrier Diodes

Product No.		Absolute Maximum Ratings (Ta=25°C)*				Electrical Characteristics (Ta=25°C)*				Package	Equivalent Circuit Diagram	
Part No.	Packaging Symbol	V _{RM} (V)	V _R (V)	I _O (A)	I _{FSM} (A) 60Hz, 1ms	V _F (V) Max.	I _F (A)	I _R (mA) Max.	V _R (V)			
New	RB551SS-30	T2R	30	20	0.5	5	0.47	0.5	0.1	20		
New	RB550SS-30	T2R	30	30	0.5	5	0.59	0.5	0.008	15		
New	RB161SS-20	T2R	30	20	1	5	0.42	1	1	20		
New	RB160SS-40	T2R	40	40	1	5	0.55	0.7	0.05	20		
	RB551V-30	TE-17	30	20	0.5	2	0.36	0.1	0.1	20		UMD2
	RB161VA-20	TR	30	20	1	5	0.42	1	1	20		TUMD2
	RB162VA-20	TR	25	20	1	5	0.40	1	1.2	20		TUMD2
	RB550VA-30	TR	30	30	1	3	0.52	1	0.03	10		TUMD2
	RB160VA-40	TR	40	40	1	5	0.55	0.7	0.05	40		TUMD2
	RB411VA-50	TR	50	20	0.5	3	0.5	0.5	0.03	10		TUMD2
	RB400VA-50	TR	50	40	0.5	3	0.55	0.5	0.05	30		TUMD2
	RB021VA-90	TR	90	90	0.2	5	0.49	0.2	0.9	90		TUMD2
	RB161M-20	TR	25	20	1	30	0.35	1	0.7	20		PMDU
	RB051M-2Y	TR	20	20	3	30	0.46	3	0.9	20		PMDU
	RB160M-30	TR	30	30	1	30	0.48	1	0.05	30		PMDU
	RB070M-30	TR	30	30	1.5	30	0.49	1.5	0.05	30		PMDU
	RB060M-30	TR	30	30	2	55	0.49	2	0.05	30		PMDU
New	RB050M-30	TR	30	30	3	55	0.51	3	0.05	30		PMDU
	RB160M-40	TR	40	40	1	30	0.51	1	0.03	40		PMDU
	RB162M-40	TR	40	40	1	30	0.55	1	0.1	40		PMDU
	RB160M-60	TR	60	60	1	30	0.55	1	0.05	60	PMDU	
	RB162M-60	TR	60	60	1	20	0.65	1	0.1	60	PMDU	
New	RB060M-60	TR	60	60	2	30	0.61	2	0.05	60	PMDU	
	RB160M-90	TR	90	90	1	30	0.73	1	0.1	90	PMDU	
	RB050LA-30	TR	—	30	3	70	0.45	3	0.15	30	PMDT	
	RB050LA-40	TR	40	40	3	70	0.55	3	0.1	40	PMDT	
	RB051LA-40	TR	40	20	3	70	0.45	3	1	20	PMDT	
	RB055LA-40	TR	40	40	3	70	0.62	3	0.1	40	PMDT	
	RB081L-20	TE25	25	20	5	70	0.45	5	0.7	20	PMDS	
New	RB055L-30	TE25	30	30	3	55	0.55	3	0.05	30	PMDS	
New	RB080L-30	TE25	30	30	5	70	0.51	5	0.15	30	PMDS	
	RB161L-40	TE25	40	20	1	70	0.4	1	1	20	PMDS	
	RB051L-40	TE25	40	20	3	70	0.45	3	1	20	PMDS	
	RB160L-40	TE25	40	40	1	70	0.55	1	0.1	40	PMDS	
	RB162L-40	TE25	40	40	1	20	0.55	1	0.5	40	PMDS	
	RB060L-40	TE25	40	40	2	70	0.5	2	1	40	PMDS	
	RB050L-40	TE25	40	40	3	70	0.55	3	1	40	PMDS	
	RB055L-40	TE25	40	40	3	40	0.65	3	0.5	40	PMDS	
	RB056L-40	TE25	40	40	3	70	0.67	3	0.05	40	PMDS	
	RB160L-60	TE25	60	60	1	30	0.58	1	1	60	PMDS	
	RB162L-60	TE25	60	60	1	20	0.65	1	0.1	60	PMDS	
	RB050L-60	TE25	60	60	2	70	0.52	2	0.1	60	PMDS	
	RB160L-90	TE25	95	90	1	30	0.73	1	0.1	90	PMDS	
	RB160A30	T-32	30	30	1	70	0.48	1	0.05	30	MSR	
	RB160A40	T-32	40	40	1	50	0.55	1	0.03	40	MSR	
	RB160A60	T-32	60	60	1	60	0.55	1	0.05	60	MSR	
	RB160A90	T-32	90	90	1	50	0.73	1	0.1	90	MSR	
	RB201A60	T-32	60	60	2	40	0.58	2	0.1	60	MSR	
	RB461F	T106	25	20	0.7	3	0.49	0.7	0.2	20	UMD3	
	RB491D	T146	25	20	1	3	0.45	1	0.2	20	SMD3	
	RB411D	T146	40	20	0.5	3	0.5	0.5	0.03	10	SMD3	
	RB400D	T146	40	40	0.5	3	0.55	0.5	0.05	30	SMD3	
	RB496KA	TR	—	20	1	5	0.43	1	0.8	10	TUMD5	
	RB496EA	TR	20	20	1	10	0.4	1	0.5	10	TSMD5	
	RB550EA	TR	30	30	0.7	15	0.49	0.7	0.05	30	TSMD5	

Note: *1 Value / element.

Power Schottky Barrier Diodes

Product No.		Absolute Maximum Ratings (Ta=25°C) *1				Electrical Characteristics (Ta=25°C) *1				Package	Equivalent Circuit Diagram
Part No.	Packaging Symbol	V _{RM} (V)	V _R (V)	I _O *2 (A)	I _{FSM} (A) 60Hz, 1/10	V _F (V) Max.	I _F (A)	I _R (mA) Max.	V _R (V)		
RB095B-30	TL	35	30	6	45	0.425	3	0.2	30	D-Pack (CPD)	
RB095B-40	TL	45	40	6	45	0.55	3	0.1	40	D-Pack (CPD)	
RB095B-60	TL	60	60	6	45	0.58	3	0.1	60	D-Pack (CPD)	
RB095B-90	TL	90	90	6	45	0.75	3	0.15	90	D-Pack (CPD)	
RB085B-30	TL	35	30	10	35	0.48	4	0.3	30	D-Pack (CPD)	
RB085B-40	TL	45	40	10	45	0.55	5	0.2	40	D-Pack (CPD)	
RB085B-90	TL	90	90	10	45	0.83	5	0.15	90	D-Pack (CPD)	
RB075B40S	TL	40	40	5	45	0.75	5	0.005	40	D-Pack (CPD)	
RB225N-40	TL	40	40	30	50	0.55	15	0.5	40	LPDS	
RB095T-40	Bulk	45	40	6	100	0.55	3	0.1	40	TO-220FN	
RB085T-40	Bulk	45	40	10	100	0.55	5	0.2	40	TO-220FN	
RB205T-40	Bulk	45	40	15	100	0.55	7.5	0.3	40	TO-220FN	
RB215T-40	Bulk	45	40	20	100	0.55	10	0.5	40	TO-220FN	
RB225T-40	Bulk	40	40	30	100	0.63	15	0.5	40	TO-220FN	
RB095T-60	Bulk	60	60	6	100	0.58	3	0.1	60	TO-220FN	
RB085T-60	Bulk	60	60	10	100	0.58	5	0.3	60	TO-220FN	
RB205T-60	Bulk	60	60	15	100	0.58	7.5	0.6	60	TO-220FN	
RB215T-60	Bulk	60	60	20	100	0.58	10	0.6	60	TO-220FN	
RB225T-60	Bulk	60	60	30	100	0.63	15	0.6	60	TO-220FN	
RB095T-90	Bulk	90	90	6	100	0.75	3	0.15	90	TO-220FN	
RB085T-90	Bulk	90	90	10	100	0.83	5	0.15	90	TO-220FN	
RB205T-90	Bulk	90	90	15	100	0.78	7.5	0.3	90	TO-220FN	
RB215T-90	Bulk	90	90	20	100	0.75	10	0.4	90	TO-220FN	
RB225T100	Bulk	100	100	30	100	0.88	15	0.4	100	TO-220FN	

Note: *1 Value / element. *2 1/2 I_O per diode.

Zener Diode Product Lineup

2-Terminal (Single) / 4-Terminal (Dual)

Package		Surface Mount Type													
		1006 Size VMN2		1406 Size VMD2		1608 Size EMD2 (SOD-523)		1712 Size UMD2 (SOD-323)		0603 Size GMD2		1913 Size TUMD2			
Equivalent Circuit Diagram															
Series name		CDZ Series		VDZ Series		EDZ Series		UDZ S Series		GDZ Series		TDZ Series			
Power (mW)		100		100		150		200		100		500			
Package symbol		T2R		T2R		TE61		TE-17		T2R		TR			
Electrical Characteristics (Ta=25°C)		Vz (V)	Iz (mA)	Vz (V)	Iz (mA)	Vz (V)	Iz (mA)	Vz (V)	Iz (mA)	Vz (V)	Iz (mA)	Vz (V)	Iz (mA)		
Voltage	3.6B	3.600 to 3.845	5	3.600 to 3.845	5	3.600 to 3.845	5	3.600 to 3.845	5	3.6	—	—	3.6	—	—
	3.9B	3.89 to 4.16	5	3.89 to 4.16	5	3.89 to 4.16	5	3.89 to 4.16	5	3.9	3.740 to 4.160	5	3.9	—	—
	4.3B	4.17 to 4.43	5	4.17 to 4.43	5	4.17 to 4.43	5	4.17 to 4.43	5	4.3	—	—	4.3	—	—
	4.7B	4.55 to 4.75	5	4.55 to 4.75	5	4.55 to 4.75	5	4.55 to 4.75	5	4.7	4.420 to 4.900	5	4.7	—	—
	5.1B	4.98 to 5.20	5	4.98 to 5.20	5	4.98 to 5.20	5	4.98 to 5.20	5	5.1	4.840 to 5.370	5	5.1	4.600 to 5.600	10
	5.6B	5.49 to 5.73	5	5.49 to 5.73	5	5.49 to 5.73	5	5.49 to 5.73	5	5.6	5.310 to 5.920	5	5.6	5.100 to 6.100	10
	6.2B	6.06 to 6.33	5	6.06 to 6.33	5	6.06 to 6.33	5	6.06 to 6.33	5	6.2	5.860 to 6.530	5	6.2	5.600 to 6.800	10
	6.8B	6.65 to 6.93	5	6.65 to 6.93	5	6.65 to 6.93	5	6.65 to 6.93	5	6.8	6.470 to 7.140	5	6.8	6.200 to 7.400	10
	7.5B	7.28 to 7.60	5	7.28 to 7.60	5	7.28 to 7.60	5	7.28 to 7.60	5	7.5	7.060 to 7.840	5	7.5	6.800 to 8.300	10
	8.2B	8.02 to 8.36	5	8.02 to 8.36	5	8.02 to 8.36	5	8.02 to 8.36	5	8.2	7.760 to 8.640	5	8.2	7.400 to 9.000	10
	9.1B	8.85 to 9.23	5	8.85 to 9.23	5	8.85 to 9.23	5	8.85 to 9.23	5	9.1	—	—	9.1	8.200 to 10.00	10
	10B	9.77 to 10.21	5	9.77 to 10.21	5	9.77 to 10.21	5	9.77 to 10.21	5	10	—	—	10	9.000 to 11.00	10
	11B	10.76 to 11.22	5	10.76 to 11.22	5	10.76 to 11.22	5	10.76 to 11.22	5	11	—	—	11	9.900 to 12.10	10
	12B	11.74 to 12.24	5	11.74 to 12.24	5	11.74 to 12.24	5	11.74 to 12.24	5	12	—	—	12	10.80 to 13.20	10
	13B	12.91 to 13.49	5	12.91 to 13.49	5	12.91 to 13.49	5	12.91 to 13.49	5	13	—	—	13	11.70 to 14.30	10
	15B	14.34 to 14.98	5	14.34 to 14.98	5	14.34 to 14.98	5	14.34 to 14.98	5	15	—	—	15	13.50 to 16.50	10
	16B	15.85 to 16.51	5	15.85 to 16.51	5	15.85 to 16.51	5	15.85 to 16.51	5	16	—	—	16	14.40 to 17.60	10
	18B	—	—	17.56 to 18.35	2	17.56 to 18.35	5	17.56 to 18.35	5	18	—	—	18	16.20 to 19.80	10
	20B	—	—	19.52 to 20.39	2	19.52 to 20.39	5	19.52 to 20.39	5	20	—	—	20	18.00 to 22.00	10
	22B	—	—	21.54 to 22.47	2	21.54 to 22.47	5	21.54 to 22.47	5	22	—	—	22	19.80 to 24.20	10
24B	—	—	23.72 to 24.78	2	23.72 to 24.78	5	23.72 to 24.78	5	24	—	—	24	21.60 to 26.40	10	
27B	—	—	26.19 to 27.53	2	26.19 to 27.53	2	26.19 to 27.53	5	27	—	—	27	24.30 to 29.70	10	
30B	—	—	29.19 to 30.69	2	29.19 to 30.69	2	29.19 to 30.69	5	30	—	—	30	27.00 to 33.00	10	
33B	—	—	32.15 to 33.79	2	32.15 to 33.79	2	32.15 to 33.79	5	33	—	—	33	—	—	—
36B	—	—	35.07 to 36.87	2	35.07 to 36.87	2	35.07 to 36.87	5	36	—	—	36	—	—	—
39B	—	—	—	—	—	—	—	—	39	—	—	39	—	—	—
Package		Surface Mount Type				Surface Mounted, Glass Type				Leaded Type		Surface Mount Type			
		1913 Size TUMD2		2616 Size PMDU (SOD-123)		4526 Size PMDS (SOD-106)		3415 Size LLDS (LL-34)		2.7xφ1.8 MSD (DO-34)		2012 Size UMD4 (SOD-343)			
Equivalent Circuit Diagram															
Series name		TFZ Series		KDZ Series		PTZ Series		RLZ Series		MTZ J Series		UMZ K Series			
Power (mW)		500		1000		1000		500		500		200			
Package symbol		TR		TR		TE25		TE-11		T-77		TL			
Electrical Characteristics (Ta=25°C)		Vz (V)	Iz (mA)	Vz (V)	Iz (mA)	Vz (V)	Iz (mA)	Vz (V)	Iz (mA)	Vz (V)	Iz (mA)	Vz (V)	Iz (mA)		
Voltage	3.6B	3.600 to 3.845	20	3.60 to 4.00	40	3.60 to 4.00	40	3.600 to 3.845	20	3.600 to 3.845	5	3.6K	3.600 to 3.845	5	
	3.9B	3.89 to 4.16	20	3.90 to 4.40	40	3.90 to 4.40	40	3.89 to 4.16	20	3.89 to 4.16	5	3.9K	3.89 to 4.16	5	
	4.3B	4.17 to 4.43	20	4.30 to 4.80	40	4.30 to 4.80	40	4.17 to 4.43	20	4.17 to 4.43	5	4.3K	4.17 to 4.43	5	
	4.7B	4.55 to 4.80	20	4.70 to 5.20	40	4.70 to 5.20	40	4.55 to 4.80	20	4.55 to 4.80	5	4.7K	4.55 to 4.75	5	
	5.1B	4.94 to 5.20	20	5.10 to 5.70	40	5.10 to 5.70	40	4.94 to 5.20	20	4.94 to 5.20	5	5.1K	4.98 to 5.20	5	
	5.6B	5.45 to 5.73	20	5.60 to 6.30	40	5.60 to 6.30	40	5.45 to 5.73	20	5.45 to 5.73	5	5.6K	5.49 to 5.73	5	
	6.2B	5.96 to 6.27	20	6.20 to 7.00	40	6.20 to 7.00	40	5.96 to 6.27	20	5.96 to 6.27	5	6.2K	6.06 to 6.33	5	
	6.8B	6.49 to 6.83	20	6.80 to 7.70	40	6.80 to 7.70	40	6.49 to 6.83	20	6.49 to 6.83	5	6.8K	6.65 to 6.93	5	
	7.5B	7.07 to 7.45	20	7.50 to 8.40	40	7.50 to 8.40	40	7.07 to 7.45	20	7.07 to 7.45	5	7.5K	7.28 to 7.60	5	
	8.2B	7.78 to 8.19	20	8.20 to 9.30	40	8.20 to 9.30	40	7.78 to 8.19	20	7.78 to 8.19	5	8.2K	8.02 to 8.36	5	
	9.1B	8.57 to 9.01	20	9.10 to 10.20	40	9.10 to 10.20	40	8.57 to 9.01	20	8.57 to 9.01	5	9.1K	8.85 to 9.23	5	
	10B	9.41 to 9.90	20	10.00 to 11.20	40	10.00 to 11.20	40	9.41 to 9.90	20	9.41 to 9.90	5	10K	9.77 to 10.21	5	
	11B	10.50 to 11.05	10	11.00 to 12.30	20	11.00 to 12.30	20	10.50 to 11.05	10	10.50 to 11.05	5	11K	10.76 to 11.22	5	
	12B	11.44 to 12.03	10	12.00 to 13.50	20	12.00 to 13.50	20	11.44 to 12.03	10	11.44 to 12.03	5	12K	11.74 to 12.24	5	
	13B	12.55 to 13.21	10	13.30 to 15.00	20	13.30 to 15.00	20	12.55 to 13.21	10	12.55 to 13.21	5	13K	12.91 to 13.49	5	
	15B	13.89 to 14.62	10	14.70 to 16.50	20	14.70 to 16.50	20	13.89 to 14.62	10	13.89 to 14.62	5	15K	14.34 to 14.98	5	
	16B	15.25 to 16.04	10	16.20 to 18.30	20	16.20 to 18.30	20	15.25 to 16.04	10	15.25 to 16.04	5	16K	15.85 to 16.51	5	
	18B	16.82 to 17.70	10	18.00 to 20.30	20	18.00 to 20.30	20	16.82 to 17.70	10	16.82 to 17.70	5	18K	17.56 to 18.35	5	
	20B	18.63 to 19.59	10	20.00 to 22.40	20	20.00 to 22.40	20	18.63 to 19.59	10	18.63 to 19.59	5	20K	19.52 to 20.39	5	
	22B	20.64 to 21.71	5	22.00 to 24.50	10	22.00 to 24.50	10	20.64 to 21.71	5	20.64 to 21.71	5	22K	21.54 to 22.47	5	
24B	22.61 to 23.77	5	24.00 to 27.60	10	24.00 to 27.60	10	22.61 to 23.77	5	22.61 to 23.77	5	24K	23.72 to 24.78	5		
27B	24.97 to 26.26	5	27.00 to 30.80	10	27.00 to 30.80	10	24.97 to 26.26	5	24.97 to 26.26	5	27K	26.19 to 27.53	5		
30B	27.70 to 29.13	5	30.00 to 34.00	10	30.00 to 34.00	10	27.70 to 29.13	5	27.70 to 29.13	5	30K	29.19 to 30.69	5		
33B	30.32 to 31.88	5	33.00 to 37.00	10	33.00 to 37.00	10	30.32 to 31.88	5	30.32 to 31.88	5	33K	32.15 to 33.79	5		
36B	32.79 to 34.49	5	36.00 to 40.00	10	36.00 to 40.00	10	32.79 to 34.49	5	32.79 to 34.49	5	36K	35.07 to 36.87	5		
39B	35.36 to 37.19	5	—	—	—	—	35.36 to 37.19	5	35.36 to 37.19	5	39K	—	—		

Note: Available voltages are displayed

Zener Arrays (2-4 Elements) for Terminal Protection Devices





Product No.		Absolute Maximum Ratings (Ta=25°C) P (mW)	Electrical Characteristics (Ta=25°C) Vz (V)		Remark	Package	Equivalent Circuit Diagram
Part No.	Packaging Symbol		Iz (mA)				
UMZ8.2T	T106	200	7.76 to 8.64	5		UMD3	
STZ6.8T	T146	200	6.47 to 7.14	5		SMD3	
VMZ6.8N	T2L	150	6.47 to 7.14	5		VMD3	
EMZ6.8N	TL	150	6.47 to 7.14	5		EMD3	
UMZ5.1N	T106	200	4.84 to 5.37	5		UMD3	
UMZ6.8N	T106	200	6.47 to 7.14	5		UMD3	
UMZ8.2N	T106	200	7.76 to 8.64	5		UMD3	
UMZ12N	T106	200	11.0 to 13.0	5		UMD3	
UMZ16N	T106	200	15.85 to 16.51	5		UMD3	
UMZ18N	T106	200	17.56 to 18.35	5	IEC61000-4-2 150pF, 330Ω	UMD3	
UMZ27N	T106	200	26.19 to 27.53	5	Contact 8kV Air 15kV	UMD3	
UMZ30N	T106	200	29.19 to 30.69	5		UMD3	
UMZ36N	T106	200	35.07 to 36.87	5		UMD3	
STZ5.6N	T146	200	5.31 to 5.92	5		SMD3	
STZ6.2N	T146	200	5.81 to 6.40	5		SMD3	
STZ6.8N	T146	200	6.47 to 7.14	5		SMD3	
EMZ6.8E	T2R	150	6.47 to 7.14	5		EMD5	
UMZ6.8EN	TR	200	6.47 to 7.14	5		UMD5	
FTZ4.3E	T148	200	4.04 to 4.57	5		SMD5	
FTZ5.6E	T148	200	5.31 to 5.92	5		SMD5	
FTZ6.8E	T148	200	6.47 to 7.14	5		SMD5	
FTZ30E	T148	200	29.19 to 30.09	5		SMD5	

Low Capacitance Zener Diodes





Part No.	Absolute Maximum Ratings (Ta=25°C) P (mW)	Electrical Characteristics (Ta=25°C)					Package	Equivalent Circuit Diagram
		Vz (V)	Iz (mA)	Ct (pF)	f (MHz)	Vr (V)		
UMZU6.2N	200	5.9 to 6.5	5	8	1	0	UMD3	
FTZU6.2E	200	5.9 to 6.5	5	8	1	0	SMD5	
CDZC6.8B	100	6.65 to 6.93	5	3	1	0	VMN2	
EDZC6.8B	150	6.65 to 6.93	5	3	1	0	EMD2	
EMZC6.8N	150	6.47 to 7.14	5	3	1	0	EMD3	
VMZT6.8N	150	6.47 to 7.14	5	7	1	0	UMD3	
UMZC6.8N	200	6.47 to 7.14	5	3	1	0	UMD3	
STZC6.8N	200	6.47 to 7.14	5	3	1	0	SMD3	
RSB12Z	100	9.6 to 14.4	5	1	1	0	VMD3	
RSB12W	150	9.6 to 14.4	5	1	1	0	EMD3	
EMZT6.8E	150	6.47 to 7.14	5	7	1	0	EMD5	
New RSB6.8JS2	150	6.00 to 8.00	5	1	1	0	EMD6	
RSB12JS2	150	9.6 to 14.4	5	1	1	0	EMD6	
New RSAC6.8CS	100	6.70 to 7.33	5	0.3	1	0	VMN2	
New RSAC16CS	100	16.49 to 17.51	5	0.3	1	0	VMN2	

* : (3), (6)pin must be open when using.

ESD Protection Devices (TVS)

Product No.		Absolute Maximum Ratings (Ta=25°C)	Electrical Characteristics (Ta=25°C)		Peak Pulse Power (W) (tp=10×1000μs)	Package	Equivalent Circuit Diagram
Part No.	Packaging Symbol	P (mW)	Vz (V)	Iz (mA)			
RSA6.1J4	T2R	150	6.10 to 7.20	1	10	EMD5	
RSA6.1EN	TR	200	6.10 to 7.20	1	30	UMD5	
RSA6.1U5	T108	200	6.10 to 7.20	1	30	SMD6	
RSA5M	TR	700	6.4 to 7.0	10	200	PMDU	
RSA12M	TR	700	13.3 to 14.7	1	200	PMDU	
RSA5L	TE25	1,000	6.45 to 7.14	10	600	PMDS	
RSA12L	TE25	1,000	13.3 to 14.7	1	600	PMDS	
RSA30L	TE25	1,000	28.5 to 31.5	1	600	PMDS	

Bidirectional Zener Diodes

Part No.	Absolute Maximum Ratings (Ta=25°C)	Electrical Characteristics (Ta=25°C)		Remark	Package	Equivalent Circuit Diagram
	P (mW)	Vz (V)	Iz (mA)			
RSB6.8CS	100	5.78 to 7.82	1		VMN2	
RSB6.8G	100	5.78 to 7.82	1		VMD2	
RSB5.6S	150	4.76 to 6.44	1		EMD2	
RSB6.8S	150	5.78 to 7.82	1		EMD2	
RSB16V	200	14.4 to 17.6	1	IEC61000-4-2	UMD2	
RSB18V	200	16.2 to 19.8	1	150pF, 330Ω	UMD2	
RSB27V	200	26.2 to 32.0	1	Contact 8kV	UMD2	
RSB16VA	500	14.4 to 17.6	1	Air 15kV	TUMD2	
RSB6.8F2	200	5.78 to 7.82	1		UMD3	
RSB16F2	200	14.4 to 17.6	1		UMD3	
RSB18F2	200	16.2 to 19.8	1		UMD3	
RSB27F2	200	26.2 to 32.0	1		UMD3	

Ultra-Low Capacitance Bidirectional Zener Diodes

Product No.		Absolute Maximum Ratings (Ta=25°C)	Electrical Characteristics (Ta=25°C)					Package	Equivalent Circuit Diagram
Part No.	Packaging Symbol	P (mW)	Vz (V)	Iz (mA)	Ct (pF)	f (MHz)	Vr (V)		
RSBC6.8CS	TR	100	6.62 to 7.24	5	8	1	0	VMN2	

Dimensions

(Unit:mm)

● Surface Mount Type

● Surface Mount, Glass Type

● Leaded Type

<p>GMD2</p>	<p>VMN2</p>	<p>LLDS (LL-34)</p>			<p>MSD (DO-34)</p>
<p>VMD2</p> <p>Each lead has same dimensions</p>	<p>VMD3</p>	<p>KMD2</p>			<p>MSR (DO-41mini)</p>
<p>EMD2 (SOD-523) (SC-79)</p> <p>Each lead has same dimensions</p>	<p>EMD3 (SOT-416) (SC-75A)</p>	<p>EMD4 (SC-75A)</p> <p>Each lead has same dimensions</p>	<p>EMD5 (SC-75A)</p> <p>Each lead has same dimensions</p>	<p>EMD6 (SC-75A)</p> <p>Each lead has same dimensions</p>	
<p>UMD2 (SOD-323) (SC-961)</p> <p>Each lead has same dimensions</p>	<p>UMD3 (SOT-323) (SC-70)</p> <p>Each lead has same dimensions</p>	<p>UMD4 (SOT-343) (SC-82)</p> <p>Each lead has same dimensions</p>	<p>UMD5 (SOT-353) (SC-88A)</p> <p>Each lead has same dimensions</p>	<p>UMD6 (SOT-363) (SC-88)</p> <p>Each lead has same dimensions</p>	
<p>SMD3 (SOT-346) (SC-59)</p> <p>Each lead has same dimensions</p>	<p>SMD5 (SC-74A)</p> <p>Each lead has same dimensions</p>	<p>SMD6 (SOT-457) (SC-74)</p> <p>Each lead has same dimensions</p>	<p>TUMD2</p> <p>Each lead has same dimensions</p>	<p>TUMD5</p> <p>Each lead has same dimensions</p>	
<p>TSMD5</p> <p>Each lead has same dimensions</p>	<p>PMDU (SOD-123)</p> <p>Each lead has same dimensions</p>	<p>PMDT</p> <p>Each lead has same dimensions</p>	<p>PMDS (SOD-106)</p> <p>Each lead has same dimensions</p>	<p>HMD8</p>	
<p>CPD (TO-252) (SC-63)</p> <p>Each lead has same dimensions</p>		<p>LPDS</p>		<p>TO-220FN</p> <p>Each lead has same dimensions</p>	

< > : JEDEC Code, () : JEITA Code

* Please refer to ROHM's website for additional information (i.e. tolerance, specifications)

MEMO

MEMO

The content specified in this document is correct as of 1st October, 2009.

No copying or reproduction of this document, in part or in whole, is permitted without the consent of ROHM Co.,Ltd.

The content specified herein is subject to change for improvement without notice.

The content specified herein is for the purpose of introducing ROHM's products (hereinafter "Products"). If you wish to use any such Product, please be sure to refer to the specifications, which can be obtained from ROHM upon request.

Examples of application circuits, circuit constants and any other information contained herein illustrate the standard usage and operations of the Products. The peripheral conditions must be taken into account when designing circuits for mass production.

Great care was taken in ensuring the accuracy of the information specified in this document. However, should you incur any damage arising from any inaccuracy or misprint of such information, ROHM shall bear no responsibility for such damage.

The technical information specified herein is intended only to show the typical functions of and examples of application circuits for the Products. ROHM does not grant you, explicitly or implicitly, any license to use or exercise intellectual property or other rights held by ROHM and other parties. ROHM shall bear no responsibility whatsoever for any dispute arising from the use of such technical information.

The Products specified in this document are intended to be used with general-use electronic equipment or devices (such as audio visual equipment, office-automation equipment, communication devices, electronic appliances and amusement devices).

The Products specified in this document are not designed to be radiation tolerant.

While ROHM always makes efforts to enhance the quality and reliability of its Products, a Product may fail or malfunction for a variety of reasons.

Please be sure to implement in your equipment using the Products safety measures to guard against the possibility of physical injury, fire or any other damage caused in the event of the failure of any Product, such as derating, redundancy, fire control and fail-safe designs. ROHM shall bear no responsibility whatsoever for your use of any Product outside of the prescribed scope or not in accordance with the instruction manual.

The Products are not designed or manufactured to be used with any equipment, device or system which requires an extremely high level of reliability the failure or malfunction of which may result in a direct threat to human life or create a risk of human injury (such as a medical instrument, transportation equipment, aerospace machinery, nuclear-reactor controller, fuel-controller or other safety device). ROHM shall bear no responsibility in any way for use of any of the Products for the above special purposes. If a Product is intended to be used for any such special purpose, please contact a ROHM sales representative before purchasing.

If you intend to export or ship overseas any Product or technology specified herein that may be controlled under the Foreign Exchange and the Foreign Trade Law, you will be required to obtain a license or permit under the Law.

ROHM Sales Offices

Contact us for further information about the products.

R0039A

San Diego +1-858-625-3630	United Kingdom +44-1-908-272400	Tianjin +86-22-23029181	Xiamen +86-592-238-5705
Atlanta +1-770-754-5972	Denmark +45-3694-4739	Shanghai +86-21-6279-2727	Zhuhai +86-756-3232-480
Boston +1-978-371-0382	Espoo +358-9725-54491	Hangzhou +86-571-87658072	Hong Kong +852-2-740-6262
Chicago +1-847-368-1006	Salò +358-2-7332234	Nanjing +86-25-8689-0015	Taipei +886-2-2500-6956
Dallas +1-972-473-3748	Oulu +358-8-5372930	Ningbo +86-574-87654201	Kaohsiung +886-7-237-0881
Denver +1-303-708-0908	Barcelona +34-9375-24320	Qingdao +86-532-8577-9312	Singapore +65-6332-2322
Detroit +1-248-348-9920	Hungary +36-1-4719338	Suzhou +86-512-6807-1300	Philippines +63-2-807-6872
Nashville +1-615-620-6700	Poland +48-22-5757213	Wuxi +86-510-82702693	Thailand +66-2-254-4890
Mexico +52-33-3123-2001	Russia +7-495-739-41-74	Guangzhou +86-20-3878-8100	Kuala Lumpur +60-3-7958-8355
Düsseldorf +49-2154-9210	Seoul +82-2-8182-700	Huizhou +86-752-205-1054	Penang +60-4-2286453
Munich +49-8999-216168	Masan +82-55-240-6234	Fuzhou +86-591-8801-8698	Kyoto +81-75-365-1218
Stuttgart +49-711-7272-370	Dalian +86-411-8230-8549	Dongguan +86-769-8393-3320	Yokohama +81-45-476-2290
France +33-1-5697-3060	Beijing +86-10-8525-2483	Shenzhen +86-755-8307-3008	

ROHM Co.,Ltd.

21 Saiin Mizosaki-cho, Ukyo-ku,
Kyoto 615-8585 Japan
TEL : +81-75-311-2121 FAX : +81-75-315-0172

www.rohm.com

ROHM
SEMICONDUCTOR